

DECEPUGLIATORI A BRACCIO IDRAULICO "DRAGON GS"

HYDRAULIC ARM BUSH CUTTERS

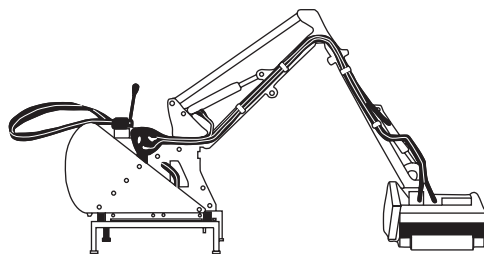

MACCHINA BASE: comandi distanza con cavi, sistema antiurto a molla sul 2° braccio - serbatoio 20 litri - doppio senso rotazione - trasmissione a cinghie - sistema autolivellante testa motore - pompa gruppo 2.

IMPIEGO: pulizia fossi - banchine - taglio siepi.

VANTAGGI: adatte per trattori piccoli, per verde pubblico e privato.

BASE MACHINE: remote control with cables, spring-operated shock pad for the second arm, 20 litre reservoir, double direction of rotation, belt drive, self-levelling system for the motor head, pump unit 2.

DESIGNED for cleaning ditches and road-side foot paths, and trimming hedges.

ADVANTAGES: suitable for small sized tractors, parks and gardens.

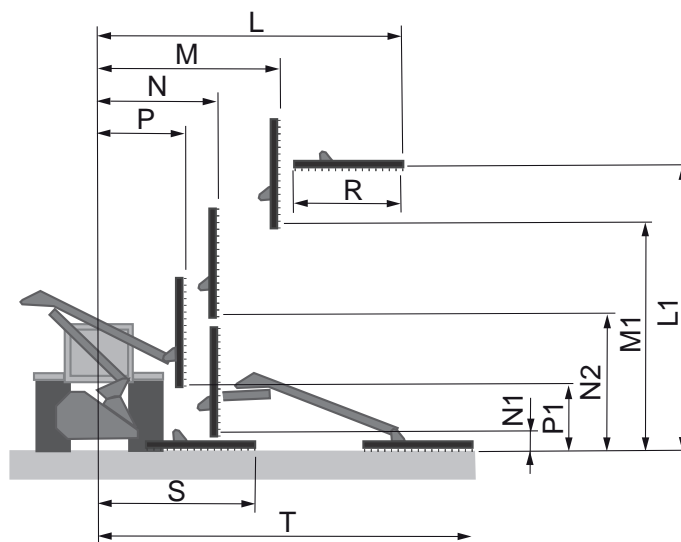
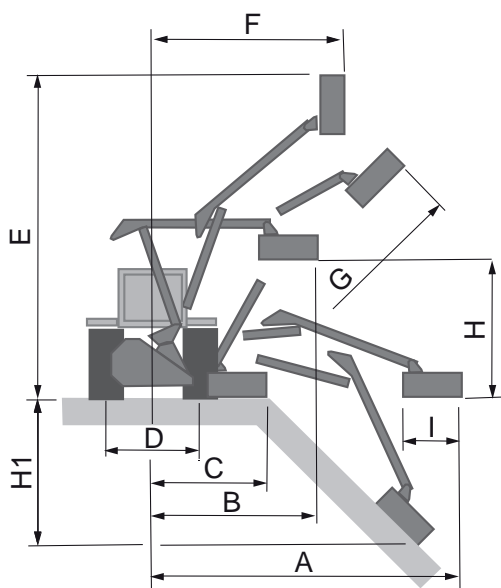

TRASMISSIONE ROTAZIONE CON CINGHIE BELT ROTATION DRIVE



MODELLO MODEL	A	B	C	D	E	F	G	H	H1	I	L	L1	M	M1	N	N1	N2	P	P1	R	S	T
	Cm	Cm	Cm	Cm	Cm	Cm	Cm	Cm	Cm	Cm	Cm	Cm	Cm	Cm	Cm	Cm	Cm	Cm	Cm	Cm	Cm	Cm
DRAGON GS 250-60	247	171	114	100	323	110	226	143	75	60	170	245	96	238	101	10	60	62	43	132	145	289
DRAGON GS 250-80	257	181	124	100	333	110	236	143	83	80												
DRAGON GS 320-60	320	170	114	100	358	182	280	170	120	60	240	310	165	250	106	10	130	76	87	132	178	354
DRAGON GS 320-80	330	180	124	100	368	182	290	170	127	80												
DRAGON GS 400-60	380	210	122	100	457	190	365	257	183	60	253	375	194	348	135	10	140	76	87	132	178	432
DRAGON GS 400-80	390	220	132	100	467	190	375	257	192	80												



CALDERONI

MODELLO MODEL			 "C"	Prezzo senza testata Price without heat
	Kg	Kg	n°	
DRAGON GS 250-60	750	367	16 + 8	Cod. DRAGONGS250-60 Cod. DRAGONGS250-80
DRAGON GS 250-80	800	378	24 + 12	
DRAGON GS 320-60	800	375	16 + 8	Cod. DRAGONGS320-60 Cod. DRAGONGS320-80
DRAGON GS 320-80	850	386	24 + 12	
DRAGON GS 400-60	850	420	16 + 8	Cod. DRAGONGS400-60 Cod. DRAGONGS400-80
DRAGON GS 400-80	900	430	24 + 12	

TESTATA / HEAD

Testata G 60 con coltelli tipo "C" - G 60 head with "C" type cutters

Cod. DGSTG60

Testata G 80 con coltelli tipo "C" - G 80 head with "C" type cutters

Cod. DGSTG80

ACCESSORI / ACCESSORIES

Scambiatore di calore con elettrovalvola automatica - Heat exchanger with automatic electric fan

Cod. DGSSC

Tenditori a vite - Screw coupling

Cod. DGSTV

Barra siepi 132 cm (ø max di taglio 2 cm) - Hedge trimmer 132 cm (max. cutting ø 2 cm)

Cod. DG SBS132

Cardano - Cardan joint

Cod. DGSC

