

IDEALE PER LA MANUTENZIONE DI GIARDINI, PARCHI, CAMPI DA GOLF E VERDE PUBBLICO
 IDEAL FOR THE MAINTENANCE OF GARDENS, PARKS, GOLF COURSES, AND PUBLIC GREEN

TRAC

TRINCIATRICE CON RACCOGLITORE CUTTING MACHINE WITH COLLECTOR









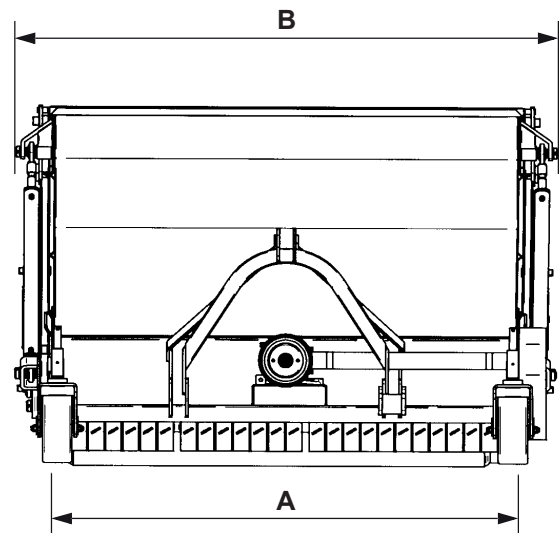
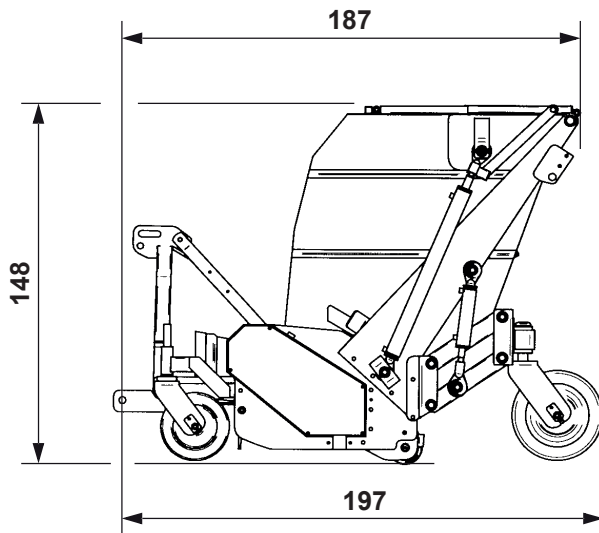

MACCHINA BASE:

- Scatola ingranaggi con ruota libera (37kW - 50CV a 540 giri/min).
- Attacco 3 punti.
- Rullo diametro 140.
- Ruote anteriori pivotanti metalliche.
- Gruppo ruote posteriori pivotanti gemellate pneumatiche.
- Cardano.

BASE MACHINE:

- Free-wheel gearbox (37kW - 50 HP at 540 RPM).
- 3-point hitch.
- 140 diameter roller.
- Front metal pivoting wheels.
- Rear dual pivoting pneumatic wheels.
- Shaft.



MODELLO MODEL								A	B		Prezzo Price
	Kg	Hp	n°	n°	n°	n°	n°	Cm	Cm	m ³	
TRAC 160	865	29÷33	24+24	24+24+24	24	24	3	160	191	1,0.	Cod. TRAC160
TRAC 190	950	33÷44	28+28	28+28+28	28	28	3	191	222	1,3	Cod. TRAC190

Sistema di scarico materiale
Discharge system

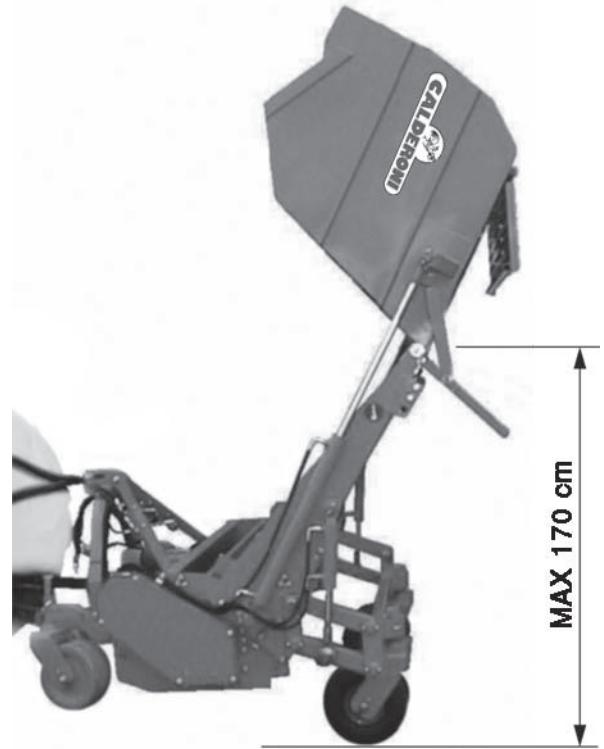

Altezza da terra
Height from the ground



CALDERONI